

# P 180 B / P 220 B / P 260 B

## PALFINGER



Many areas of use. One recipe for success.



## Impressive Performance Data.

Three platforms. One design concept. PALFINGER PLATFORMS offers an intelligent platform concept in the P 180 B, P 220 B and P 260 B trio of access platforms with far and away the best performance in the 3.5 t class.





## Easy Pick Up & Go

In addition to their performance data, the three impress with their easy handling, their rugged yet lightweight aluminium construction and an array of comfort functions that make an operator's life a whole lot easier. Ideal as a rental or for municipal applications - the platforms meet the highest demands on profitability and work safety required in the "pick up & go" business.

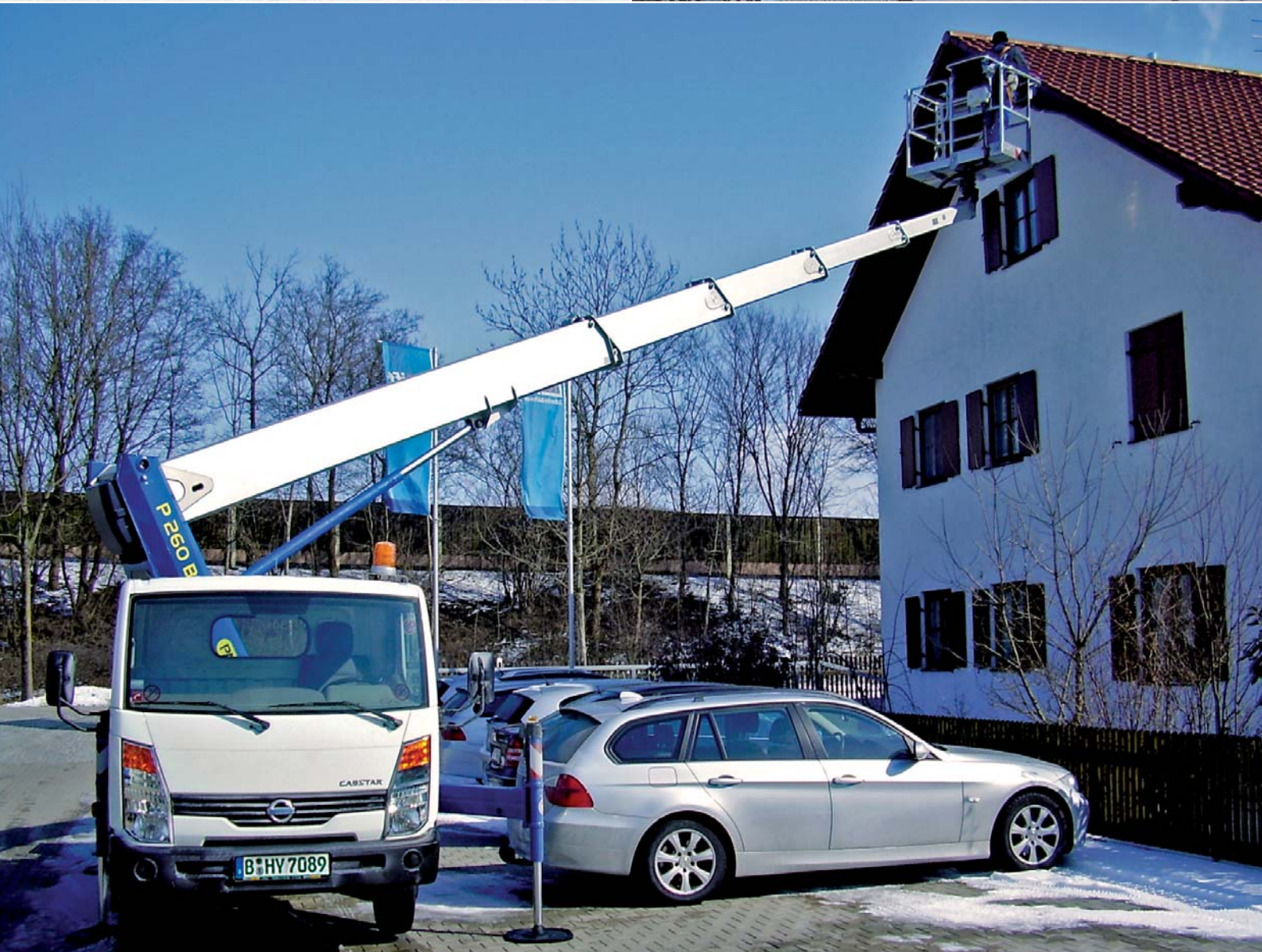



# P 180 B



## P 180 B Working range

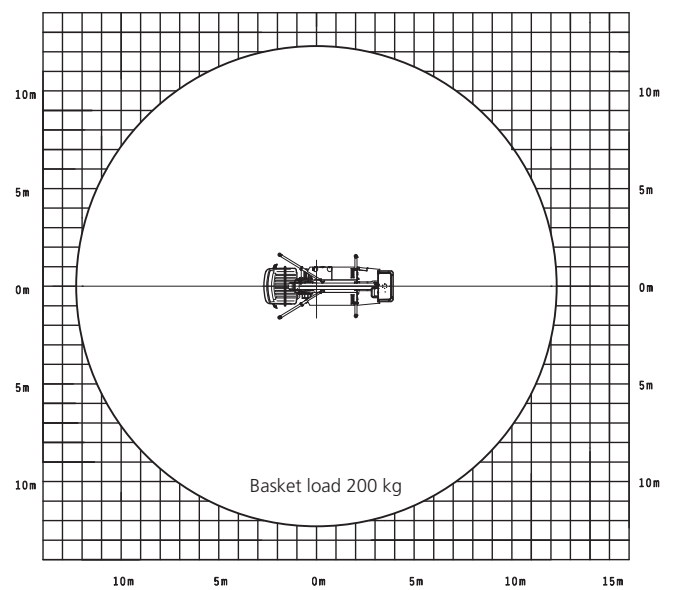
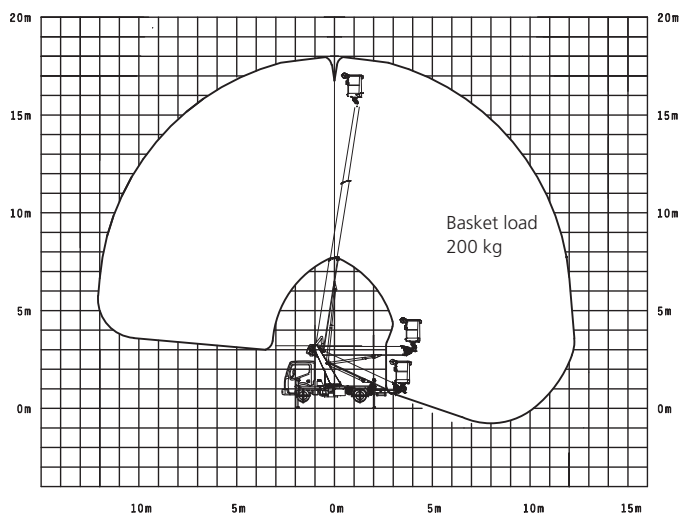

# A Busy Ant in Municipal Use

## Technical Data P 180 B

Max. working height	17.9 m
Max. basket floor height	15.9 m
Circular working range with 100 kg basket load	11.5 m
Length in transport position**	6.68 m
Width in transport position**	2.15 m
Height in transport position**	2.95 m
Angle of slope	9°
4 hydraulically extendable outriggers max. stabilizer spread*	3.4 m
4 hydraulically extendable outriggers min. stabilizer spread*	2.15 m

\*) stabilizer spread from outer edge to outer edge

\*\*) depending on the chassis and the remaining pay load

Max. permissible inclination	5°
Slewing range	500°
Design	Extruded aluminum hexagonal tubes
Telescopes in the lifting boom	2
Workman basket (LxWxH)	1.4 x 0.7 x 1.1 m
Hydraulic basket pivot drive: pivoting range	2 x 90°
Max. permissible load	200 kg

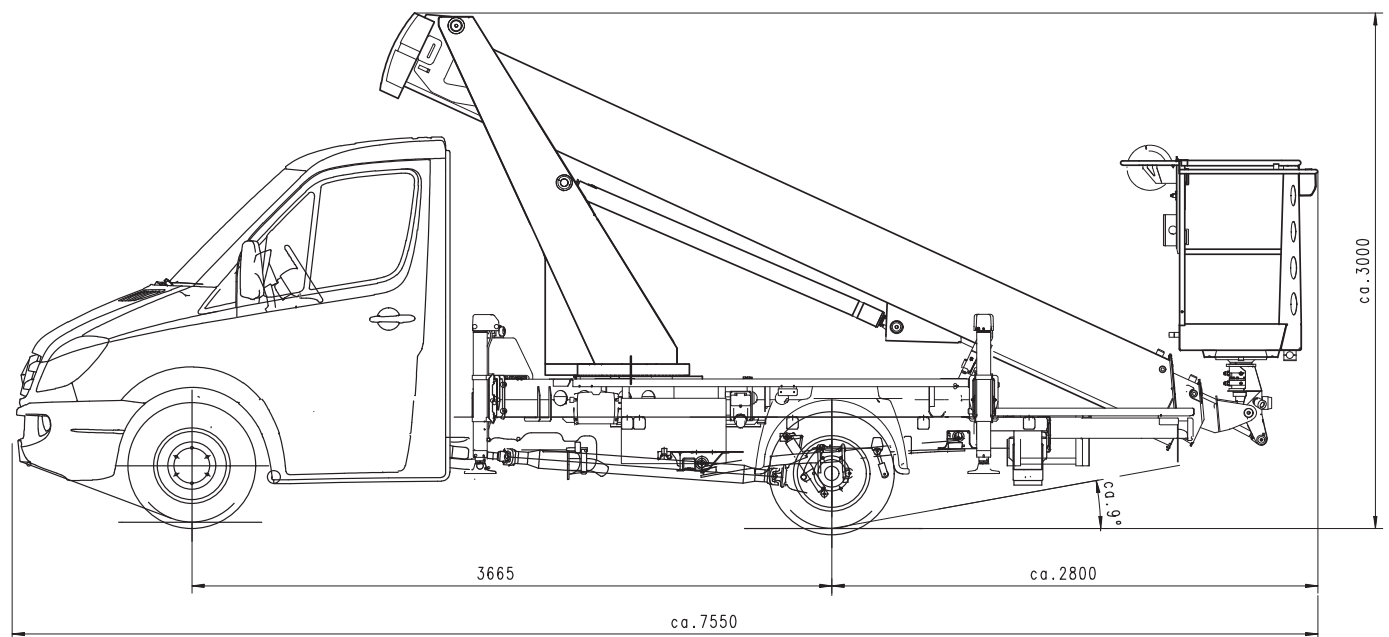



# P 220 B



## P 220 B Working range

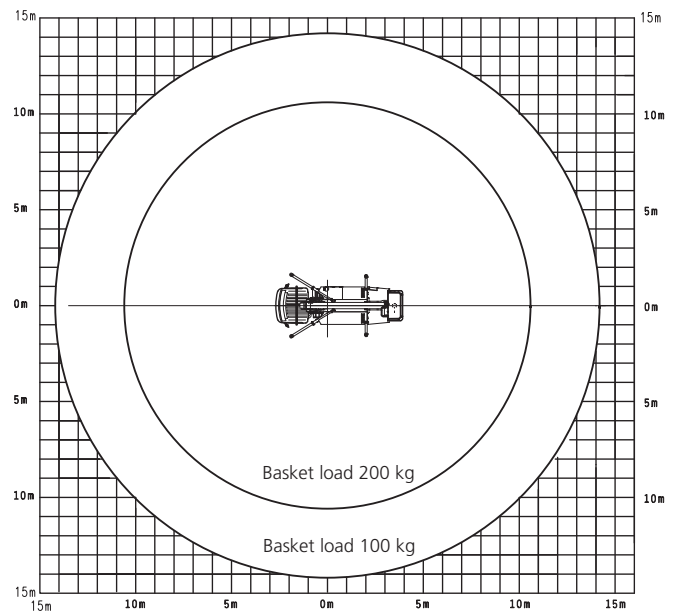
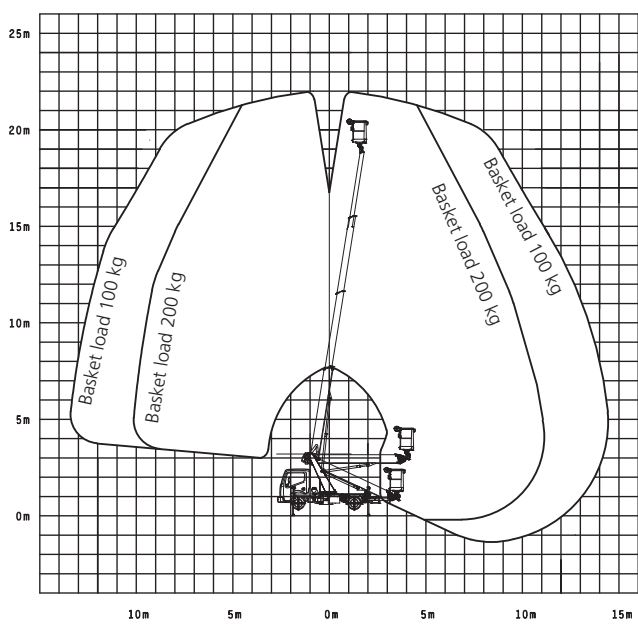

# New Standard in the Standard Class

## Technical Data P 220B

Max. working height	21.9 m
Max. basket floor height	19.9 m
Circular working range with 100 kg basket load	14.2 m
Length in transport position**	6.68 m
Width in transport position**	2.15 m
Height in transport position**	2.95 m
Angle of slope	9°
4 hydraulically extendable outriggers max. stabilizer spread*	3.4 m
4 hydraulically extendable outriggers min. stabilizer spread*	2.15 m

\*) stabilizer spread from outer edge to outer edge

\*\*) depending on the chassis and the remaining pay load

Max. permissible inclination	5°
Slewing range	500°
Design	Extruded aluminum hexagonal tubes
Telescopes in the lifting boom	3
Workman basket (LxWxH)	1.4 x 0.7 x 1.1 m
Hydraulic basket pivot drive: pivoting range	2 x 90°
Max. permissible load	200 kg

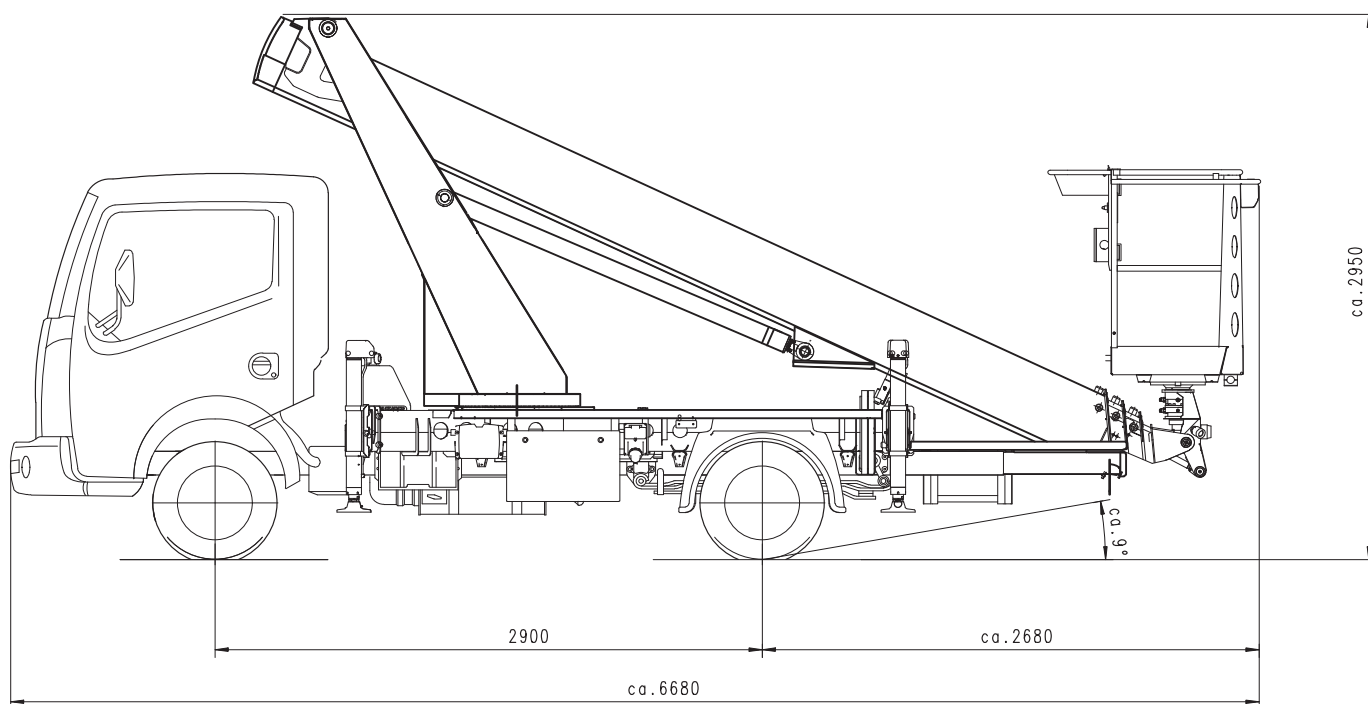



# P 260 B



## P 260 B Working range

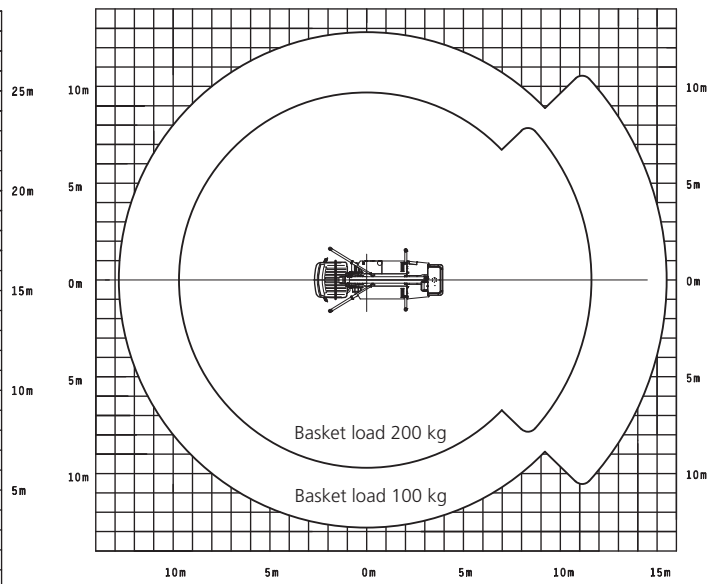
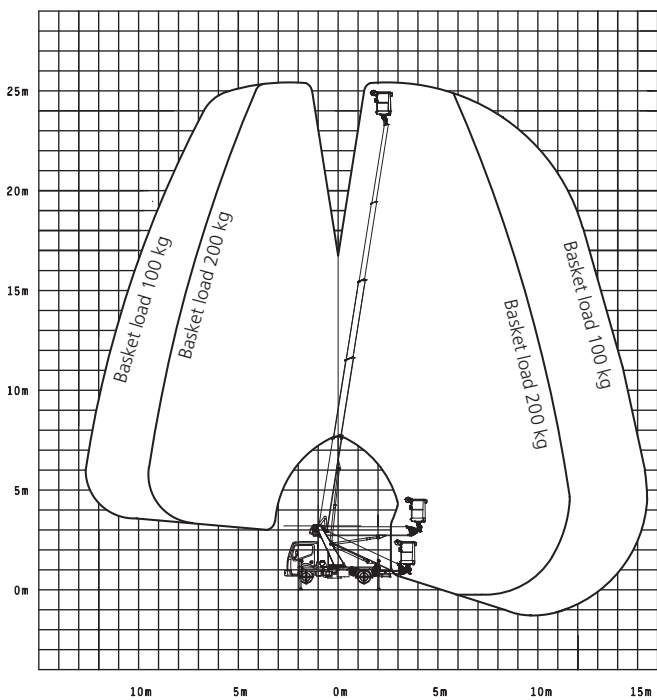



# The Alpha Machine in the 3.5 t Class

## Technical Data P 260 B

Max. working height	25.6 m
Max. basket floor height	23.6 m
Max. horizontal outreach to the rear (with 100 kg basket load)	15.5 m
Max. horizontal outreach laterally (with 100 kg basket load)	12.8 m
Max. horizontal outreach to the front (with 100 kg basket load)	12.8 m
Length in transport position**	6.68 m
Width in transport position**	2.15 m
Height in transport position**	2.95 m
Angle of slope	9°
4 hydraulically extendable outriggers max. stabilizer spread*	3.4 m
4 hydraulically extendable outriggers min. stabilizer spread*	2.15 m

\*) stabilizer spread from outer edge to outer edge

\*\*) depending on the chassis

Max. permissible inclination	5°
Slewing range	500°
Design	Extruded aluminum hexagonal tubes
Telescopes in the lifting boom	4
Workman basket (LxWxH)	1.4 x 0.7 x 1.1 m
Hydraulic basket pivot drive: pivoting range	2 x 90°
Max. permissible load	200 kg

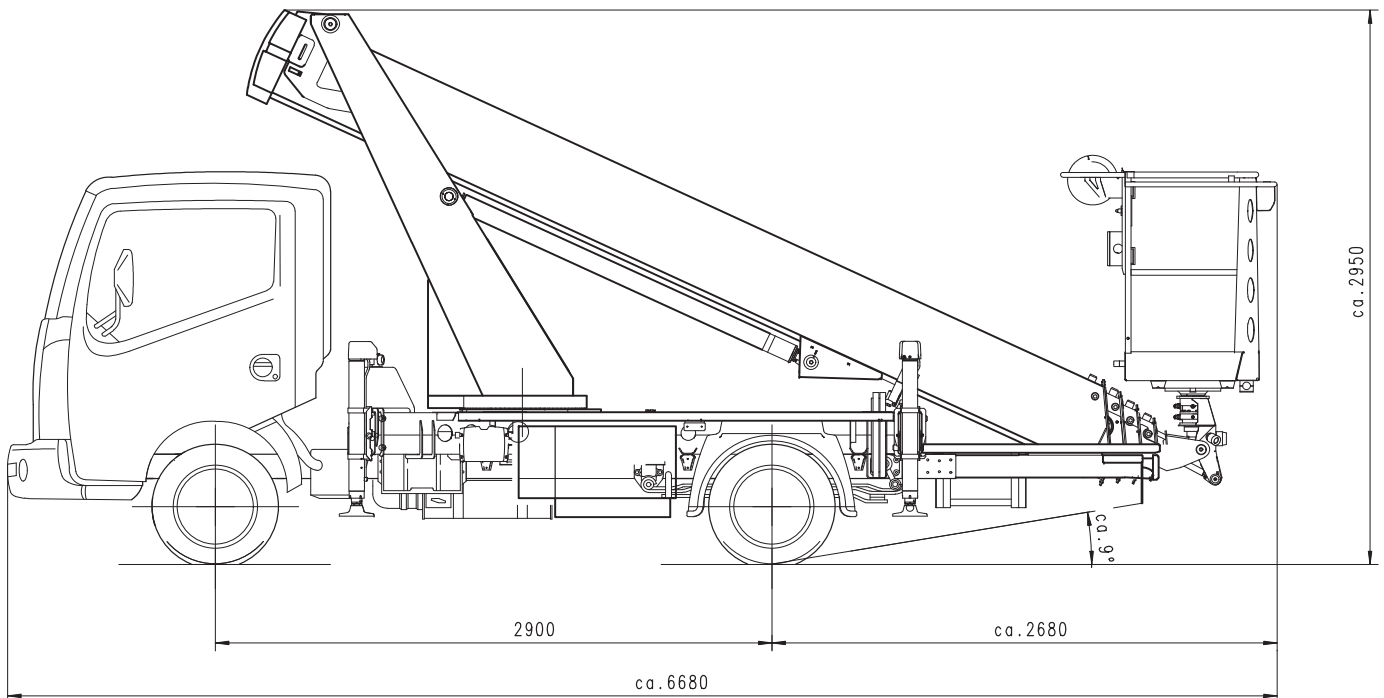



# Powerful Arguments



## Workman Basket

The sturdy aluminium workman basket includes a self-closing door for easy, upright access, a handrail with protruding pinch guard, a lockable sweep hole to facilitate cleaning and an integrated tool shelf. What more could you ask for in a workman basket.

The workman basket has a slewing area of 180°, and the outreach is fully adjustable from the basket in accordance with the load. All four stabilizers can be clearly controlled from the basket for maximum comfort.



## Efficient Control System

Sensitive electronically regulated proportional control of all movements from the workman basket and the base. Standard safety and comfort functions include outrigger control from the workman basket, automatic outrigger system with automatic set-up levelling and ground clearance wheel monitoring system, as well as automatic return to the transport position, including retraction of the outriggers (home function).

All platforms have simple hydraulic emergency operation at the base and emergency operation (emergency manual lowering valve) in the workman basket.



## 5° Set-Up Accuracy

The working range is automatically optimised in line with the set-up pitch measured to achieve a maximum outreach in every work situation.

The workman basket automatically compensates any remaining tilting of the vehicle.



## Slewing within the vehicle width

The ergonomically designed column enables the truck mounted access platform to be slewed within the width of the contours of the exterior mirrors. Street traffic is therefore not interrupted.

The stabilizers can be positioned within the vehicle's width.



## Hydraulics

Load-bearing cylinders are equipped with redundant block valves. This is unique in the industry!



# Far ahead

## Internal routing

All power guides, cables and telescopic cylinders are internally routed in the boom system. This provides optimal protection against damage and weather. The vehicle's outer appearance is marked by smooth surfaces and a clear alignment.



## Variable Hydraulic Outriggers

Controlled from the workman basket, the hydraulic outriggers, which can be extended horizontally to variable lengths on each side, guarantee a high level of flexibility and optimise the working range. Using various outrigger modes, it is possible to adjust perfectly to the required terrain and restricted space conditions.

The pitch of the turntable is also monitored and the possible working range is calculated automatically.



## Safety ground pads

The innovative safety ground pads guarantee the securest grounding and the optimal pressure distribution on the floor. This important component between the platform and the ground comes standard.



## Ease of servicing

Extensive service functions are available for our access platforms: Operating hours counter, error data storage, diagnostic tools and remote diagnostic equipment via wireless modem/cable. The electronic components of all three models are equipped with the largest possible number of identical parts to ensure maximum security of supply.



## Safety Concept

Numerous safety features make the trio the safest access platforms in their class: Unique in the 3.5 t class, not only does the lifting boom cylinder have two downstream shut-off valves but every stabiliser cylinder also has redundantly designed shut-off valves! An integrated ground clearance wheel monitoring system, safety lugs in the workman basket and an optional synthetic basket with insulation package leave nothing to be desired.





Your Reliable Partner

KP-PREIHEM 1+E  
E 04/10, K 06/11, D 04/10



**Krefeld** – Germany



**Löbau** – Germany