

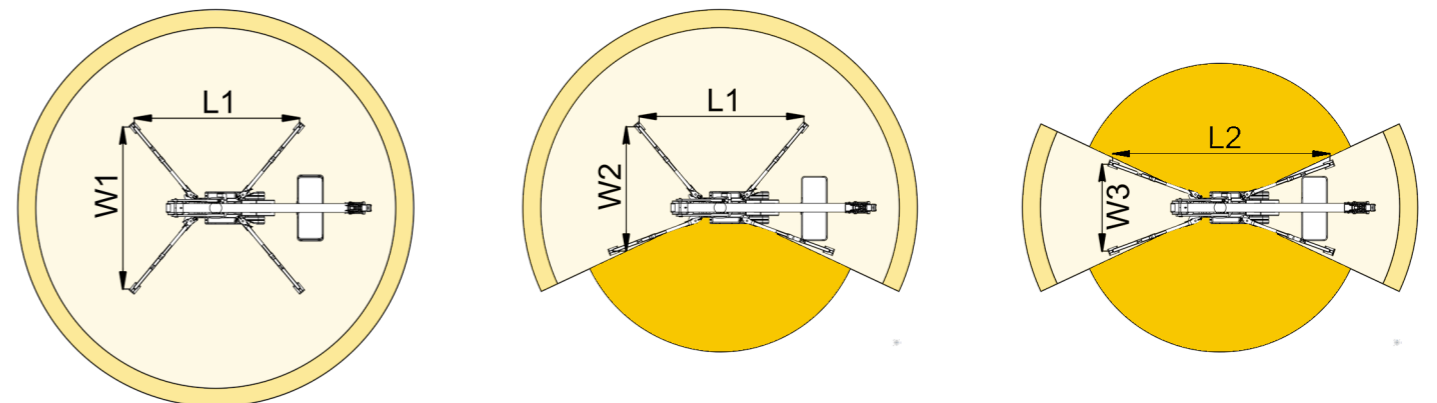

22,3 m ↑
10,3 m →
250 Kg 👤 👤

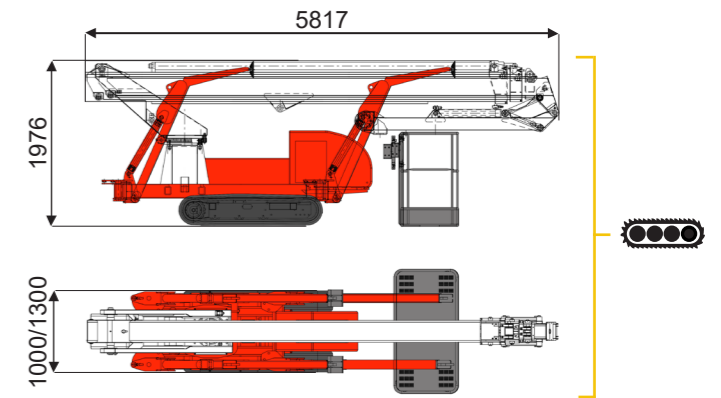
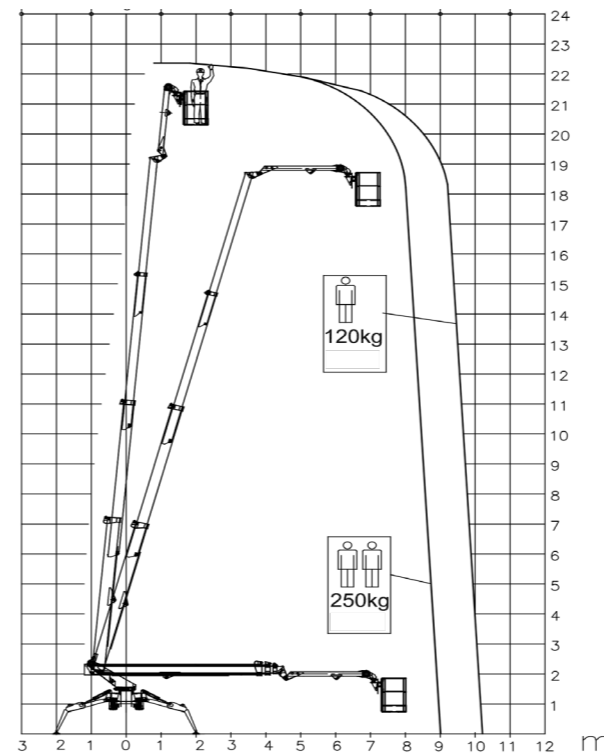

9 m	10,3 m	6 m	L1	L2	W1	W2	W3
250 kg	120 kg	120/250 kg	4900 mm	6250 mm	4350 mm	3550 mm	2750 mm

BI-ENERGY
Diesel+AC



TSJ 23.1/C-R 22.3 m 10,2 m 250 kg 170° 660° 150x70 cm 90°+80° 2,75-4,35 m 36% 29% 2,4 km/h 3100 kg 19 kN 1,45 kN/m² 3,55 kN/m²

Available version:

- BI-ENERGY (DIESEL+AC)
- ECO (DC+AC)
- HYBRID (DIESEL+DC)

Characteristics and technical data are informative only and subjected to change without notice.