



F12 TS

MONOFASE O TRIFASE



MODELLO F 12 TS

PIATTAFORMA SOSPESA MOTORIZZATA



12000

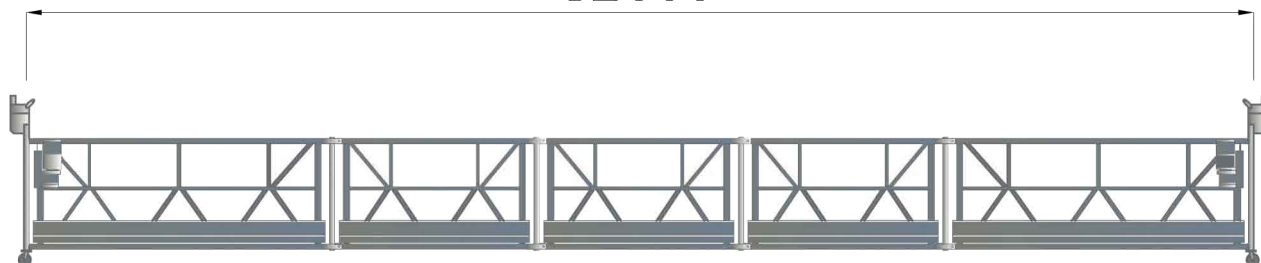

VERSIONE T

12000

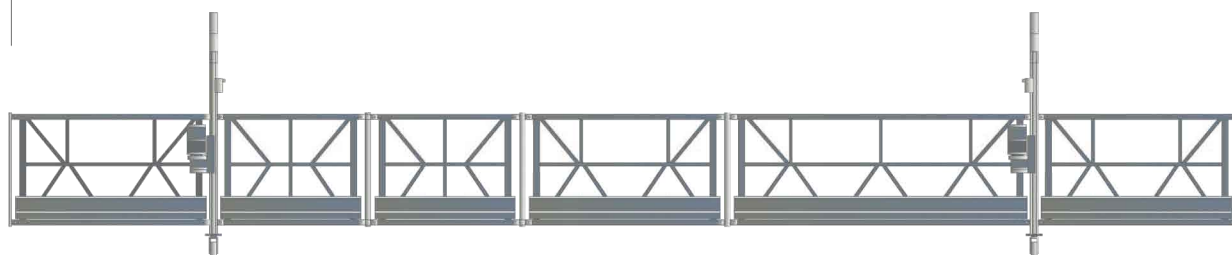

VERSIONE S

PIATTAFORMA SOSPESA MOTORIZZATA

DATI TECNICI

TECHNICAL DATA

DESCRIZIONE

DESCRIPTION

lunghezza max piattaforma	length maximum base	12 mt
velocità di spostamento verticale	width plain of job	10 mt/min
dimensioni larghezza massima	max width dimensions	0,70 mt
persone ammesse	persons admitted	4
potenza motore	motor power	Kw 0,75x2
potenza motore	motor power	Kw 1,1x2
frequenza	frequency	50/60 Hz
portata massima	maximum capacity	500 Kg.
altezza massima	max height	100 mt.



F12 TS

MONOFASE O TRIFASE

VERSIONE T

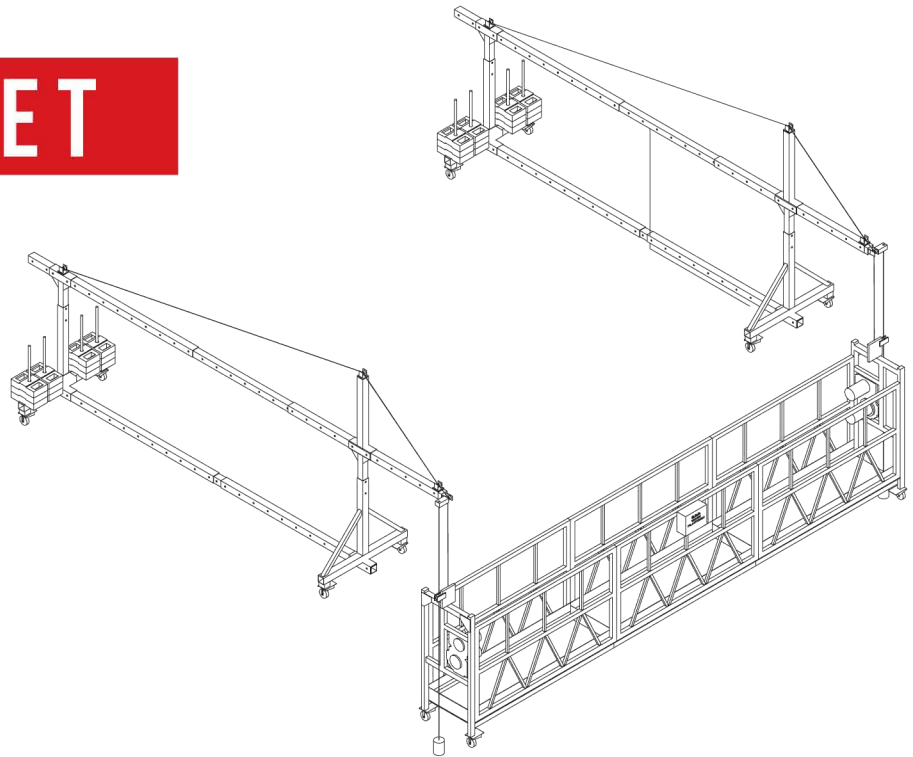

VERSIONE S

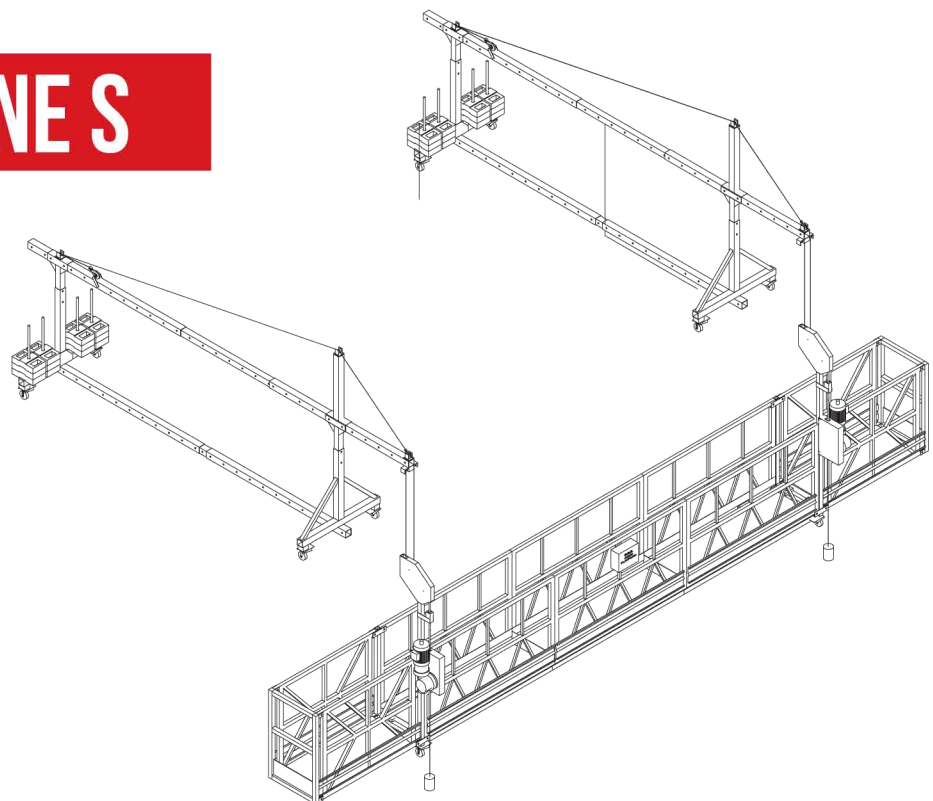

GRC



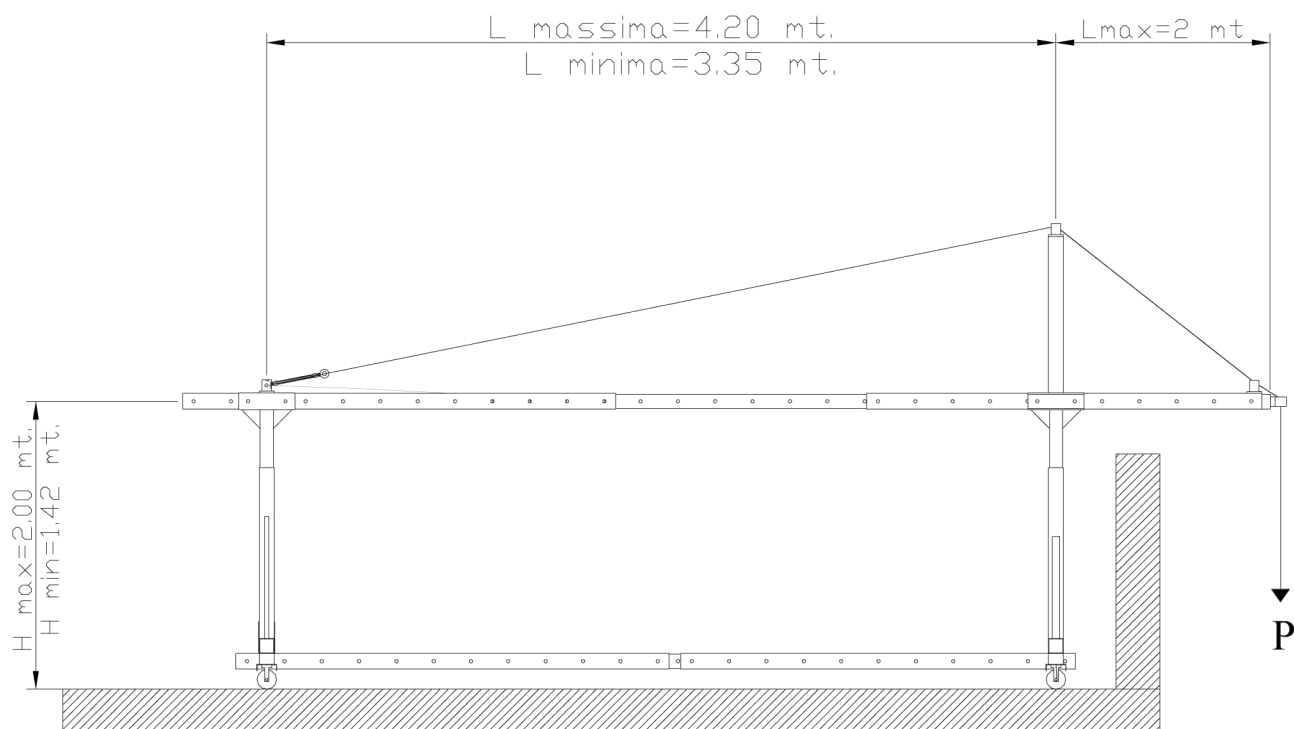

SCHEMA SOSPENSIONE SEMPLICE

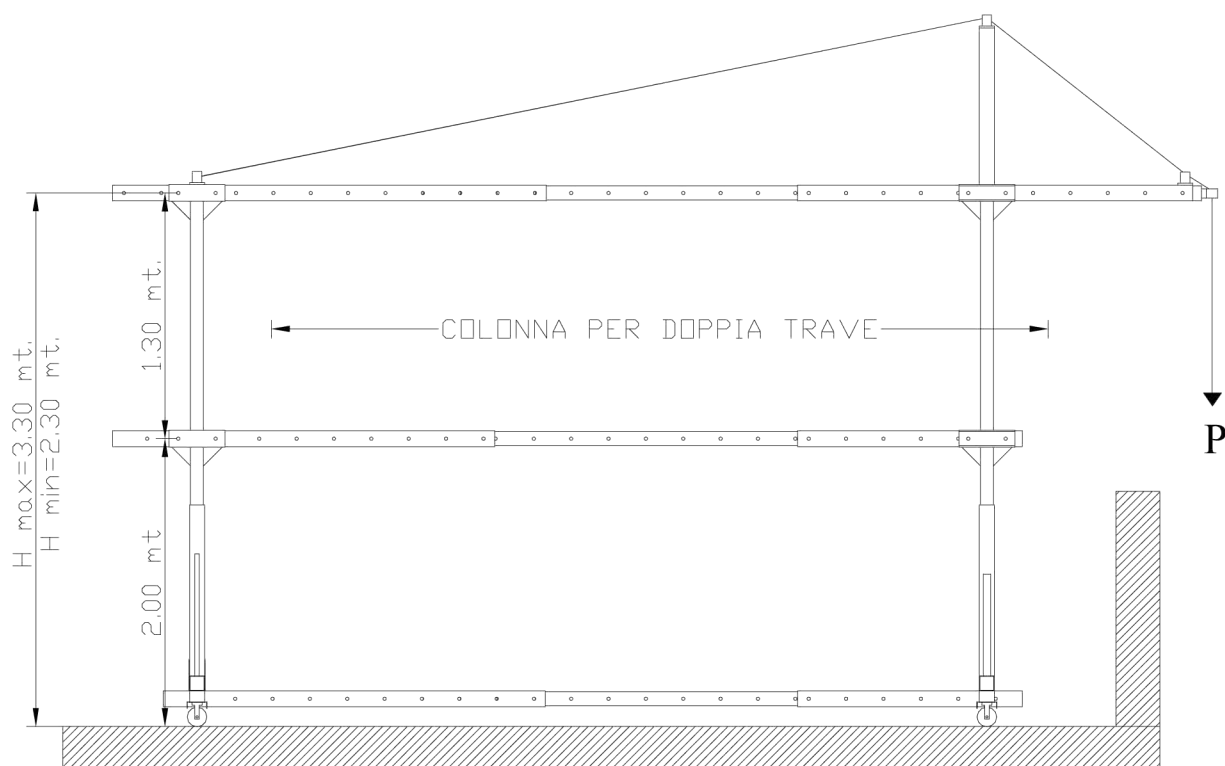

SCHEMA DOPPIA TRAVE

SCHEMA TRAVE RETICOLARE

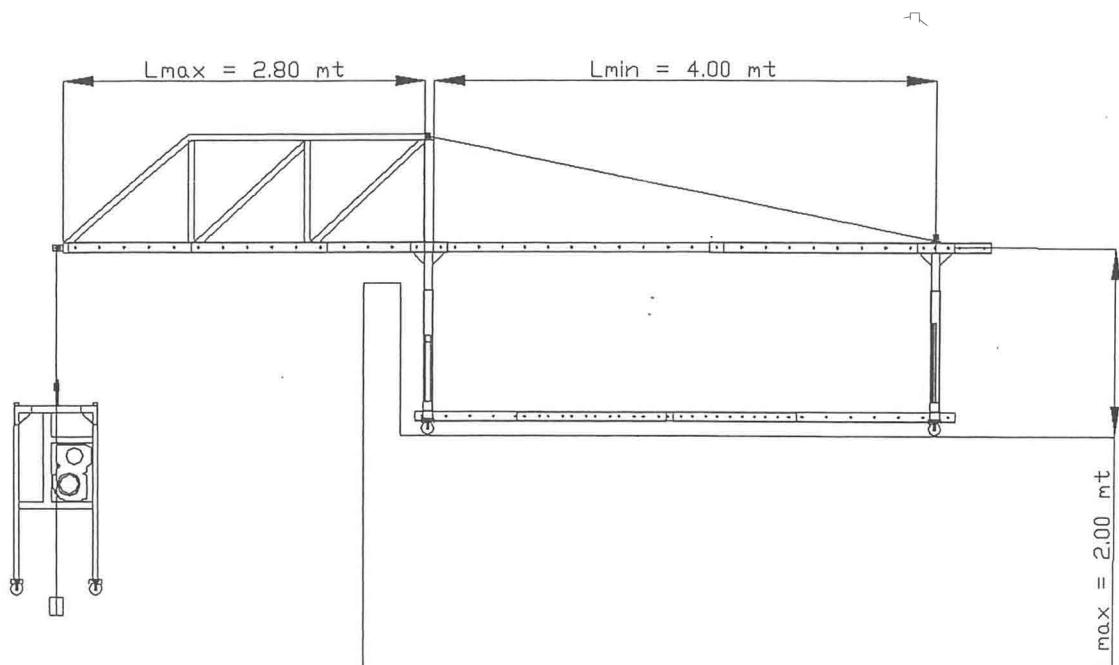
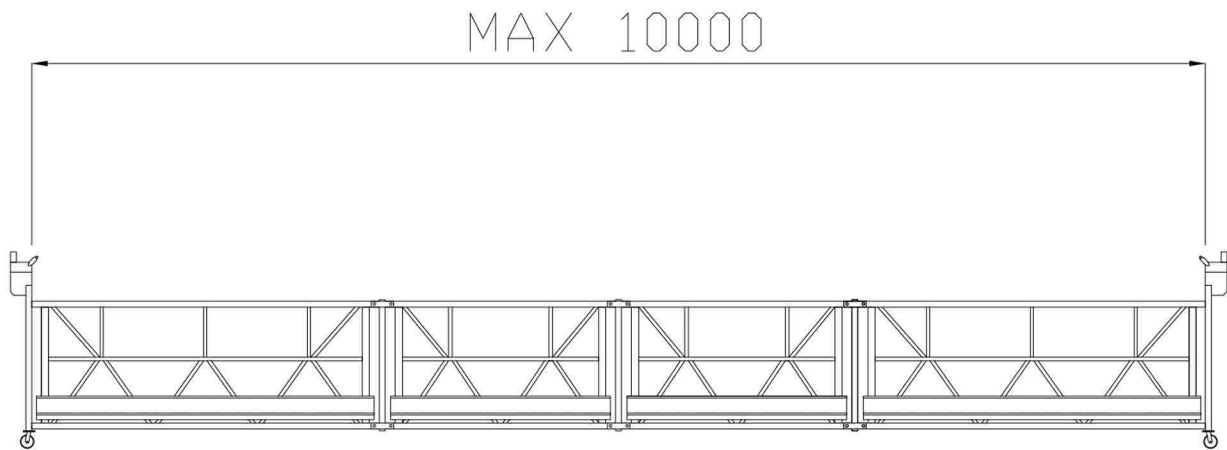

NOTE

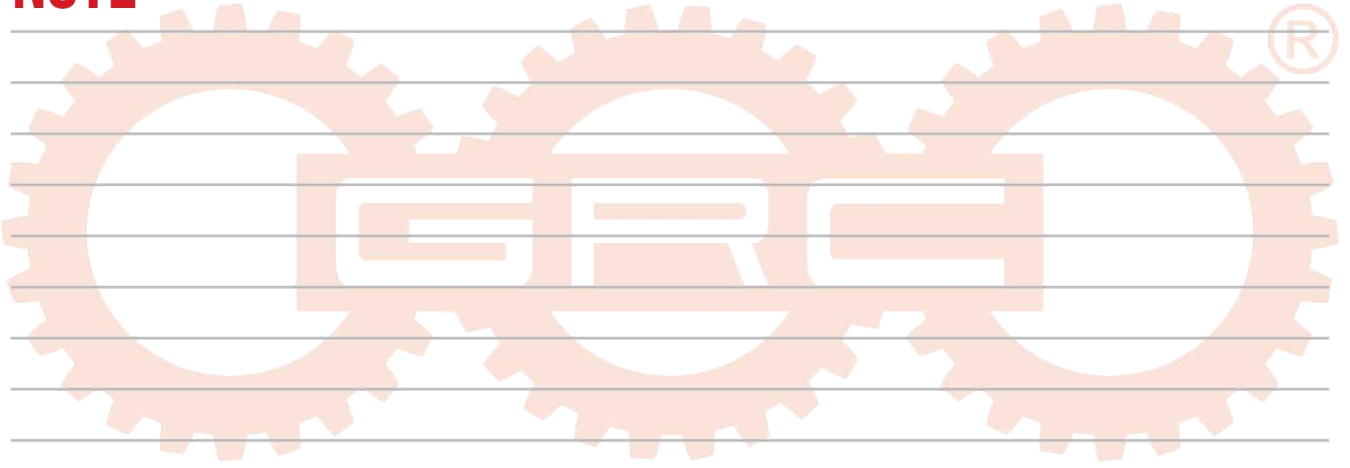

NOTE



NOTE

